

TM 11-6130-413-12

TECHNICAL MANUAL

**OPERATOR'S AND ORGANIZATIONAL
MAINTENANCE MANUAL**

**BATTERY CHARGER-ANALYZER AN/USM-432
(NSN 6130-01-055-1574)**

This copy is a reprint which includes current
pages from Change 1.

HEADQUARTERS, DEPARTMENT OF THE ARMY

31 MARCH 1980

CHANGE }
No. 1 }

HEADQUARTERS
DEPARTMENT OF THE ARMY
WASHINGTON, DC, 7 October 1981

**OPERATOR'S AND ORGANIZATIONAL MAINTENANCE MANUAL
BATTERY CHARGER-ANALYZER AN/USM-432(NSN 6130-01 -055-1 574)**

TM 11-6130-413-12, 31 March 1980, is changed as follows:

- 1. New or changed material is indicated by a vertical bar in the margin.
- 2. Remove old pages and insert new pages as indicated below:

<i>Remove pages</i>	<i>Insert pages</i>
a	a
1-1 and 1-2	1-1 and 1-2
2-1 and 2-2	2-1 and 2-2
2-3	2-3
3-3 and 3-4	3-3 and 3-4
4-3	4-3
D-3 through D-5	D-3 through D-5

File this change in front of the publication for reference purposes.

By Order of the Secretary of the Army

official:
ROBERT M. JOYCE
Brigadier General, United States Army
The Adjutant General

E. C. MEYER
General, United States Army
Chief of Staff

DISTRIBUTION:
To redistributed in accordance with Special List.

WARNINGS

HIGH VOLTAGE is used in this equipment DEATH ON CONTACT may result if safety precaution are not observed. Be careful not to come in contact with high voltage connections or any power connections when repairing or adjusting this equipment. Turn off the power and discharge all capacitors before making any connections or doing any work inside the equipment.

Battery Charger-Analyzer AN/USM-432 should be used only with a properly GROUNDED AC POWER SOURCE.

EXTREME HEAT builds up on the back of the AN/USM-432 during the battery discharge cycle. Do not touch the back of the unit or **SERIOUS BURNS** will result.

WARNINGS
DANGEROUS CHEMICALS ARE USED IN
NICKEL-CADMIUM BATTERIES

The electrolyte used in nickel-cadmium batteries contains potassium hydroxide (KOH), which is a caustic chemical agent. Serious and deep burns of body tissue will result if the electrolyte comes in contact with the eyes or any part of the body. Use rubber gloves, rubber apron, and protective goggles when handling the electrolyte. If accidental contact with the electrolyte is made, use ONLY clean water and immediately (seconds count) flush contaminated areas. Continue flushing with large quantities of clean water. Seek medical attention without delay.

EXPLOSIVE GASES ARE GENERATED BY
NICKEL-CADMIUM BATTERIES

Hydrogen and oxygen gases are generated in explosive proportion while the nickel-cadmium battery is being charged. Charge the nickel-cadmium battery in a well-ventilated area to reduce concentrations of explosive gases. Turn off the battery charger before connecting or disconnecting the nickel-cadmium battery to prevent arcing. Do not use matches or an open flame in the charging area. Arcs, flames, or sparks in the charging area will ignite the gases and cause an explosion. The battery box cover must be removed and the battery case vent plug (if used) must be open when charging.

DO NOT MIX SULPHURIC ACID AND KOH

The electrolyte used in nickel-cadmium batteries react violently to the sulphuric acid used in the more common lead-acid types of batteries. DO NOT add sulphuric acid electrolyte to the battery; the mixing of the acid and KOH electrolytes will cause a violent reaction which could result in the splattering of the mixture into the eyes and onto the skin. Every effort must be made to keep nickel-cadmium batteries as far away as possible from lead-acid batteries. Do not use the same tools and materials such as screwdrivers, wrenches, syringes, hydrometers, and gloves for both types of batteries. Any trace of acid or acid fumes will permanently damage nickel-cadmium batteries on contact.

WARNINGS

BATTERY SHOP SAFETY PRACTICES

Nickel-cadmium battery maintenance personnel should be thoroughly trained in the use of charging, discharging, and test procedures. The employment of properly trained personnel in the maintenance of nickel-cadmium batteries cannot be overemphasized. The nickel-cadmium battery shop must be used **ONLY** to maintain nickel-cadmium batteries. Anything associated with lead-acid batteries should never come in contact with nickel-cadmium batteries, including acid fumes. In addition to the equipment required to maintain nickel-cadmium batteries; the nickel-cadmium battery shop should have adequate ventilation; deluge shower, eyewash fountain, and fire extinguisher (CO₂).

TIGHTENING TERMINAL SCREWS AND STUDS

Be extremely careful when tightening terminal screws and studs. Bodily injury and damage to the equipment may result if the torque wrench accidentally causes a short circuit.

WARNINGS

Battery Charger-Analyzer AN/USM-432 is HEAVY. Use two-man lift whenever unpacking or moving the unit.

Adequate ventilation should be provided while using TRICHLOROTRIFLUOROETHANE. Prolonged breathing of vapor should be avoided. The solvent should not be used near heat or open flame; the products of decomposition are toxic and irritating. Since TRICHLOROTRIFLUOROETHANE dissolves natural oils, prolonged contact with skin should be avoided. When necessary, use gloves which the solvent cannot penetrate. If the solvent is taken internally, consult a physician immediately.

To be usable for cleaning, the COMPRESSED AIR source must limit the nozzle pressure to no more than 29 pounds per square inch gauge (PSIG). Goggles must be worn at all times while cleaning with compressed air.

CAUTION

ACID CONTAMINATES NICKEL-CADMIUM BATTERIES

Every effort must be made to keep nickel-cadmium batteries as far away as possible from lead-acid batteries because lead-acid batteries contain sulphuric acid. Do not use the same tools and materials, such as screwdrivers, wrenches, syringes, hydrometer, and gloves for both types of batteries. Any trace of acid or acid fumes will permanently damage nickel-cadmium batteries on contact.

TECHNICAL MANUAL }
 NO. 11-6130-413-12 }

HEADQUARTERS
 DEPARTMENT OF THE ARMY
 WASHINGTON, DC, 31 MARCH 1980

**OPERATOR'S AND ORGANIZATIONAL MAINTENANCE MANUAL
 BATTERY CHARGER-ANALYZER AN/USM-432
 (NSN 6130-01 -055-T574)**

REPORTING ERRORS AND RECOMMENDING IMPROVEMENTS

You can help improve this manual. If you find any mistakes or if you know of a way to improve the procedures, please let us know.

Mail your letter, DA Form 2028 (Recommended Changes to Publications and Blank Forms), or DA Form 2028-2 located in back of this manual direct to: Commander, US Army Communications and Electronics Materiel Readiness Command, ATTN: DRSEL-ME-MQ, Fort Monmouth, NJ 07703.

In any case, a reply will be furnished direct to you.

		Paragraphs	Pages
CHAPTER	1.	INTRODUCTION	
Section	I.	GENERAL	
		Scope	1-1
		Indexes of Publications	1-2
		Forms and Records	1-3
		Administrative Stooage	1-4
		Destruction of Army Electronics Material	1-5
		Equipment Improvement Recommendations (EIR).	1-6
	II.	DESCRIPTION AND DATA	
		Purpose and Use	1-7
		System Application	1-8
		Tabulated Data	1-9
		Equipment Supplied	1-10
CHAPTER	2.	SERVICE UPON RECEIPT AND INSTALLATION	
Section	I.	SERVICE UPON RECEIPT OF EQUIPMENT	
		Unpacking	2-1
		Checking Unpacked Equipment.	2-2
	II.	INSTALLATION INSTRUCTIONS	
		Tools, Test Equipment and Materials Required for Installation	2-3
		Installation Instructions.	2-4
CHAPTER	3.	OPERATING INSTRUCTIONS	
Section	I.	CONTROLS AND INDICATORS	
		General	3-1
		Controls and Indicators	3-2
	II.	OPERATION UNDER USUAL AND UNUSUAL CONDITIONS	
		Operating Procedures	3-3
		Damage from Improper Control Settings	3-4
		Procedures for Shutdown	3-5
		Operation Under Unusual Conditions	3-6
CHAPTER	4.	OPERATOR/ORGANIZATIONAL MAINTENANCE INSTRUCTIONS	
Section	I.	TOOLS AND EQUIPMENT	
		Scope of Organizational Maintenance	4-1
		Tools, Materials and Test Equipment Requird for Organizational Maintenance	4-2
	II.	REPAINTING AND REFINISHING INSTRUCTIONS	
		General	4-3
		Repainting and Refinishing	4-4
	III.	PREVENTIVE MAINTENANCE CHECKS	
		General	4-5
		Preventive Maintenance Checks.	4-6
		Cleaning	4-7
Section	IV.	TROUBLESHOOTING	
		Troubleshooting Procedures	4-8
		Removal and Replacement of Knobs	4-9

		Pages
APPENDIX	A. REFERENCES	A-1
	B. Components of End Item List (Not Applicable)	
	C. Additional Authorization List (Not Applicable)	
	D. Maintenance Allocation	D-1
Section	I. Introduction	D-1
	II. Maintenance Allocation Chart	D-3
	III. Tool and test equipment requirements	D-4
	VI. Remarks	D-5

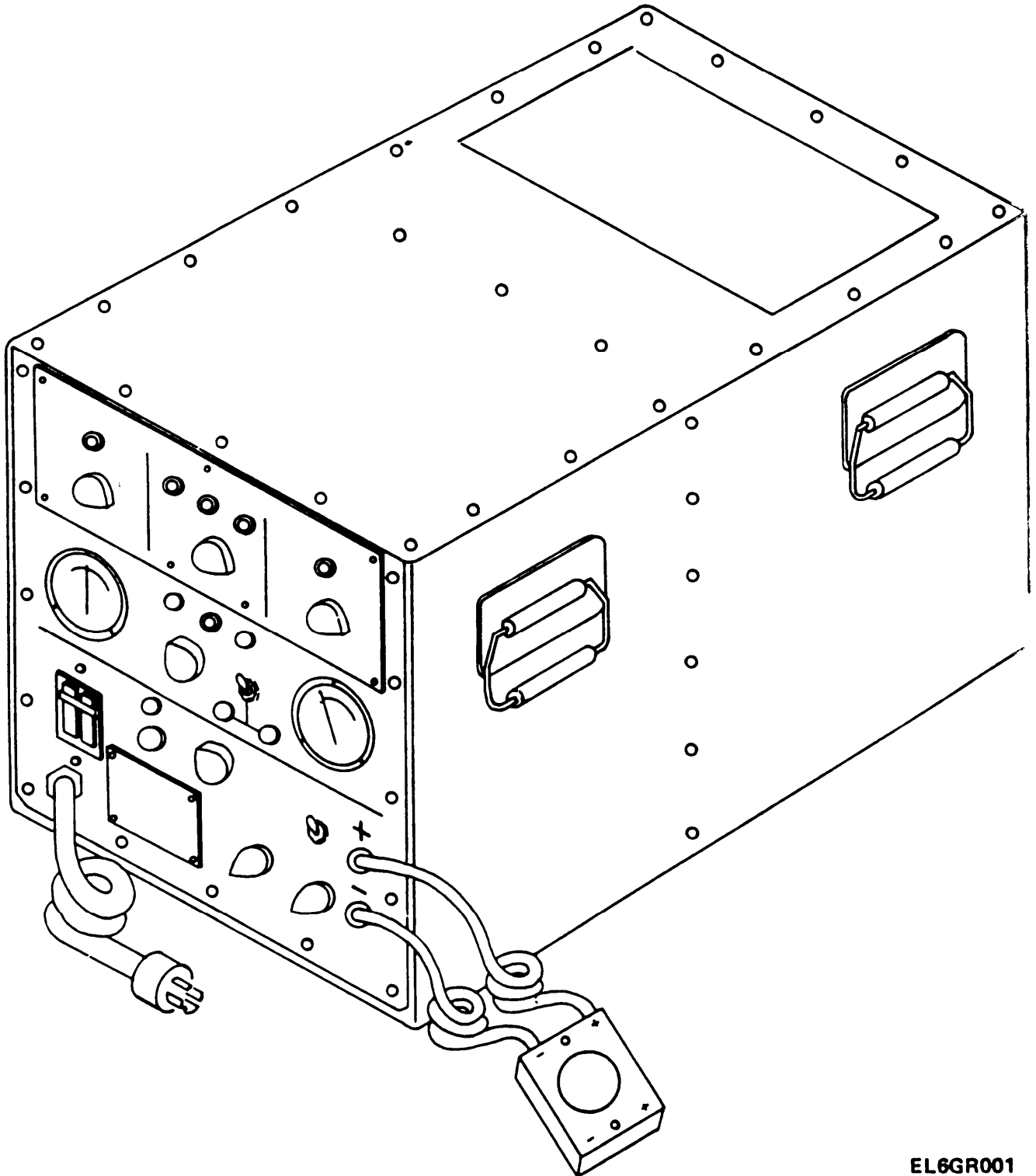

EL6GR001

Figure 1-1. Battery Charger-Analyzer. AN/USM-432.

CHAPTER 1

INTRODUCTION

Section 1. GENERAL

1-1. Scope

a. This manual describes Battery Charger-Analyzer AN/USM-432 (fig. 1-1) and covers its installation operation, function, and maintenance. It includes operation under usual and unusual conditions, cleaning and inspection of the equipment and replacement of parts available to the organizational maintenance repairman.

b. Throughout this manual Battery Charger-Analyzer AN/USM-432 will be referred to as charger/analyzer.

c. Appendix A contains a list of publications applicable to this equipment. Appendix D contains the maintenance allocation and repair operations to be performed at the appropriate maintenance categories.

1-2. Index of Technical Publications

Refer to the latest issue of DA Pam 310-4 to determine whether there are new editions, changes, or additional publications pertaining to the equipment.

1-3. Maintenance Forms, Records, and Reports

a. Reports of Maintenance and Unsatisfactory Equipment. Department of the Army forms and procedures used for equipment maintenance will be those prescribed by TM 38-750, The Army Maintenance Management System (Army).

b. Report of Packaging and Handling Deficiencies. Fill out and forward SF 364 (Report of Discrepancy (ROD)) as prescribed in AR 735-11-2/DLAR 4140.55/NAVMATINST 4355.73/AFR 400-54/MCO 4430.3E.

c. Discrepancy in Shipment Report (DISREP) (SF 361). Fill out and forward Discrepancy in Shipment Report (DISREP) (SF 361) as prescribed in AR 55-38/NAVSUPINST 4610.33B/AFR 75-18/MCO P4610.19C/DLAR 4500.15.

1-4. Administrative Storage

Administrative storage of equipment issued to and used by Army activities will have preventive maintenance performed in accordance with the PMCS charts before storing. When removing the equipment from administrative storage, the PMCS should be performed to assure operational readiness. The original shipping container should be retained for repacking of equipment for shipment or limited storage.

1-5. Destruction of Army Electronics Material

Demolition and destruction of electronic equipment will be under the direction of the commander and in accordance with TM 750-244-2.

1-6. Reporting Equipment Improvement Recommendations (EIR)

If your charger-analyzer needs improvement, let us know. Send us an EIR. You, the user, are the only one who can tell us what you don't like about your equipment. Let us know why you don't like the design. Tell us why a procedure is hard to perform. Put it on an SF 368 (Quality Deficiency Report). Mail it to Commander, US Army Communications-Electronics Command, ATTN: DRSEL-ME-MQ, Fort Monmouth, New Jersey 07703. We'll send you a reply.

Section II. DESCRIPTION AND DATA

1-7. Purpose and Use

The charger/analyzer is intended for use as an item of support equipment for charging and testing nickel-cadmium batteries used on certain types of aircraft. The charger/analyzer is a self-contained unit, utilizing automatically-programmed charge

and discharge circuits for servicing various types of vented 24-volt (19- or 20-cell) nickel-cadmium batteries with capacities ranging from 5 to 40 AH (ampere hours). All operator controls and instrumentation are accessible from the front panel. The unit is furnished with integral input and output.

power cables and requires no additional special interconnecting wiring or external power source cabling. Input leads are 5-foot, flexible, rubber-covered stranded copper, and terminated with an appropriate plug for connection to designated ac power source. Output leads are 6-foot, flexible, rubber-covered stranded copper, and terminated with a type MS25182 battery disconnect plug for connection to an MS3509 aircraft. storage battery electrical receptacle. The charger/analyzer uses solid-state circuitry with internal heat sinks and convection cooling and requires no external source of cooling air.

a. Charger Mode. When used in the charger mode of operation, the unit is capable of pulse-charging a nickel-cadmium battery from any state of discharge to full capacity within one hour, based on the recommended charging rate in the appropriate battery manual. When the battery terminal voltage reaches the charge termination voltage specified for the battery, the charging current is reduced to a topping charge until the cycle is terminated automatically by the charge timer.

b. Discharge Mode. The unit is also capable of discharging batteries at a rate equal to, or greater than, their one-hour ampere rating. If the battery terminal voltage reaches a specified volts-per-cell before the one hour of discharge is completed the unit will indicate a failure and suspend operation.

1-8. System Application

Operation of the charger/analyzer is fully automatic, once the operator programs the necessary controls and cycling to match the battery under test/ charge. Normal operation generally includes the following five phases:

NOTE

Phase 3, 4, and 5 are automatic, including termination except for periodic voltage checks of each cell which may be accomplished during charging cycles. Operator can reset unit to any phase at any time.

a. Phase 1: Capacity Test. Battery is discharged at rated capacity (for 1 hour). If battery reaches a terminal voltage of 0.95 volts $\pm 5\%$ per cell before 1 hour elapses, the charger/analyzer indicates a FAIL condition and battery is checked to determine if it is faulty. If 1 hour or more elapses before battery cell voltage is 0.95 volts $\pm 5\%$ the battery is considered

as acceptable and the operator can determine its capacity.

b. Phase 2: Equalization Discharge. All cells are discharged simultaneously to zero volts. (The operator must short individual cells as their voltage drops below 0.5 volts.)

c. Phase 3: Initial Charge. Battery is pulse-charged to full capacity. One hour is required for this phase on 5 AH to 50 AH batteries.

d. Phase 4: Capacity Test. Battery is discharged at the 1 hour rate. If a terminal voltage of less than 0.95 volts per cell $\pm 5\%$ is not reached within 1 hour, charger/analyzer indicates that battery passes capacity test and indicates battery capacity. If the battery reaches 0.95 volts $\pm 5\%$ per cell before one hour, unit indicates a rejected battery and terminates operation at this point, not continuing to phase 5.

e. Phase 5: Final Charge. Battery is pulse-charged to full capacity. One hour is required for this phase.

1-9. Tabulated Data

Item	Characteristic
Dimensions	17 in. w. (43.2 cm) x 25 in. D (63.5 cm) x 16.75 in. H. (42.5 cm).
Weight	166 lb. (75.5 kg) crated 143 lb. (65 kg) uncrated.
Power Input Requirements	188 volts ac 253 volts ac, single phase, 50/60 Hz 30 amperes.
Output Characteristics.	Groups of 120 Hz pulses, to pulse charge 5 to 40 A H NiCad batteries (19 or 20 cells).
Duty Cycle	Continuous
Operating Temperature Range	+32° F. (0° C.) to +113° F. (45° C.).
Nonoperating (storage) Temperature Range	-79° F. (-62° C.) to +160° F. (+71° C.).
Operating Altitude Range	0 to 5000 ft.
Non-operation Altitude Range.	0 to 8000 ft.
Relative Humidity	to 95%.
Protective Features	Open-circuit protection polarity-reversal protection; short-circuit protection overload protection.
Total Heat Dissipation	1200 watts maximum

1-10. Equipment Supplied

All necessary cables for input and output electrical connections are furnished integral to the equipment. Other than voltmeter leads, no additional equipment is required to ensure that the charger/analyzer performs its intended function.

CHAPTER 2

SERVICE UPON RECEIPT AND INSTALLATION

Section 1. SERVICE UPON RECEIPT OF EQUIPMENT

2-1. Unpacking (fig. 2-1)

a. Packing Data. The battery charger analyzer is shipped in a heavy duty carton with adequate internal cardboard cartons and packing material designed to provide maximum protection against mechanical shock and other damage during transit.

b. Material Handling. No special material handling equipment is necessary for unpacking or handling of the crated unit. However, care should be taken when moving the equipment to avoid any excessive shock or vibration. Four men using reasonable precautions, may carry the crated unit to the installation area.

c. Unpacking Instructions (fig. 2-1).

(1) Cut tape sealing top of box, fold back flaps and turn box on side.

(2) Remove bagged unit and set upright on base. Discard carton.

(3) Slit open bag and peel away from box, slit open inner box and remove unit. Note that handles are folded down against sides of unit; to grasp handles, cut away sides of box.

(4) Grasp side handles (4- man lift), lift unit out of box and place unit on convenient work surface for inspection.

2-2. Checking Unpacked Equipment

a. Inspect the equipment for damage that may have occurred during shipment. If the equipment has been damaged, fill out and forward DD Form 6 (Report of Packaging and Handling Deficiencies) (para 1-3b).

b. Check to see that the equipment is complete as listed on the packing slip. Report all discrepancies in accordance with TM 38-750.

c. Check to see whether the equipment has been modified. If the equipment has been modified, the MWO number will appear on the front panel near the nomenclature plate. Check also to see whether all MWO's current at the time the equipment is placed in use have been applied.

NOTE

Current MWO's applicable to the equipment are listed in DA Pam 310-7.

d. Check the latest issue of DA Pam 310-4 (never more than 1 year old) and its latest changes (never more than 6 months old) to see whether you have the latest editions of all applicable maintenance literature (equipment issued by depots may have been in stock for some time and may contain superseded manuals).

Section II. INSTALLATION INSTRUCTIONS

2-3. Tools, Test Equipment, and Materials Required for Installation

No special tools are required to install the battery charger/analyzer. Common hand tools associated with electronic equipment installation and maintenance are sufficient for all installation tasks. A multimeter can be used for simple electrical measurement.

2-4. Installation Instructions

The unit is completely self-maintained, with all controls and indicator accessible at the front panel. It is intended for placement on a work bench, with free air flow, and does not require special racks or mounts.

a. The charger/analyzer is equipped with a four prong ac power plug; however, only three of the four wires in the cable are used (red, black and green). Should it be necessary to change the ac power plug, note that the green wire is the ground and the white wire is not used.

b. Interconnections. The charger/analyzer is designed to operate from ac supply voltages ranging from 188 volts to 253 volts, single-phase, 50/60 Hz, 30 amperes. As shipped, the charger/analyzer power transformer taps are connected for operation from a 230-volt (nominal) supply source (207 volts ac to 253 volts at). If the available source voltage differs, it will be necessary to reconnect internal taps to match available power source before equipment is placed into operation. To set internal transformer (T1) primary winding taps, refer to figure 2-2 and proceed as follows:

WARNINGS

Disconnect power source before changing primary winding taps. Dangerous voltages are present when power source is connected.

Do not attempt to make internal connections or adjustments unless another person, capable of first aid is present.

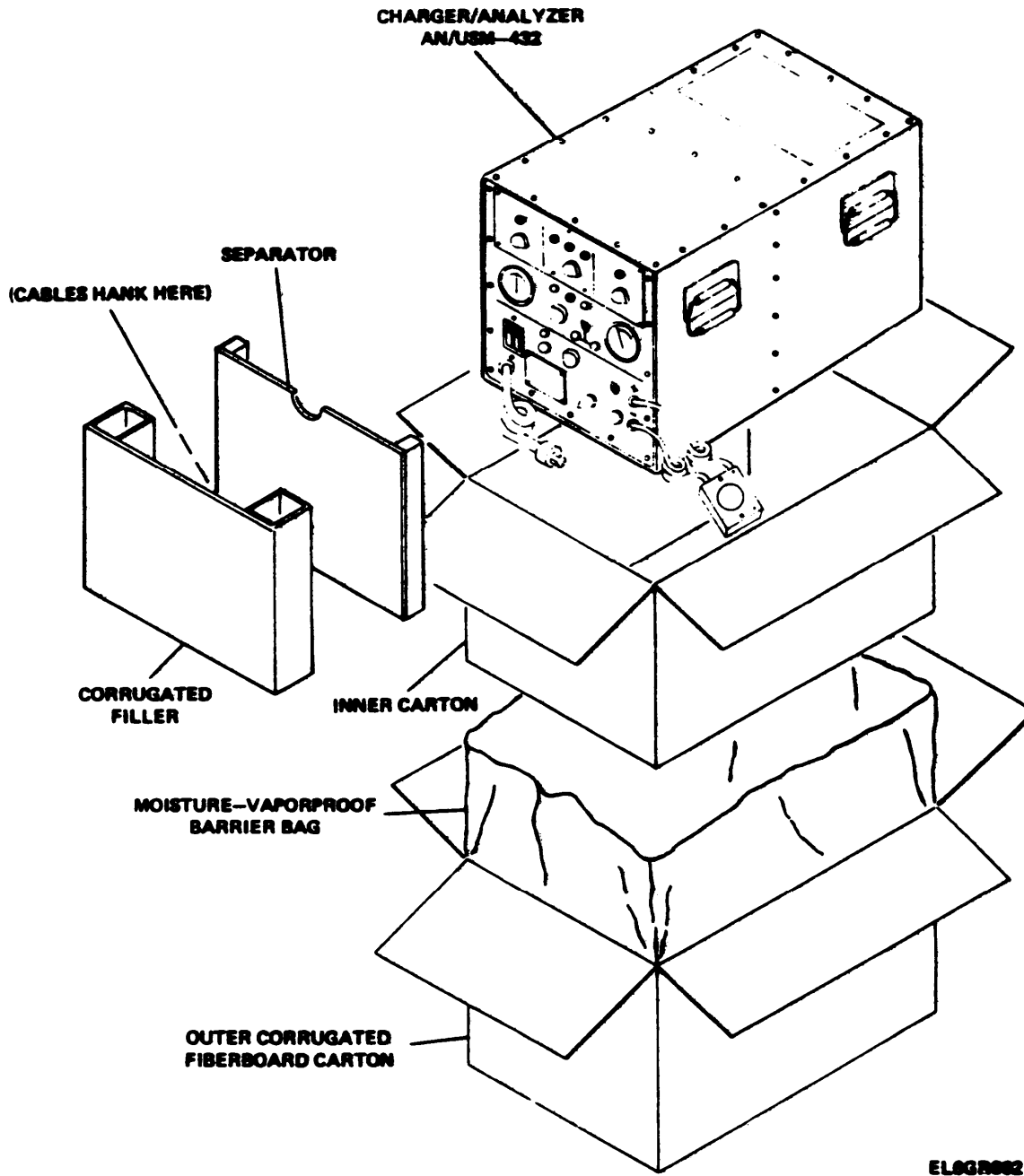

Figure 2-1. AN/USN-432 unpacking

CAUTION

Do not connect equipment to power source until all tap connections are made or equipment damage may result.

(1) Using ac voltmeter, measure ac supply voltage input directly at source receptacle.

(2) Remove the 25 screws from the top cover of the charger/analyzer.

(3) Connect the transformer taps as indicated below to correspond with the available power source:

<i>Power Source</i>	<i>Transformer Terminal Connections</i>
207v ac to 253v ac (230V ac nominal)	Black wire to 230V terminal
187v ac to 229v ac (208v ac nominal)	Black wire to 208V terminal

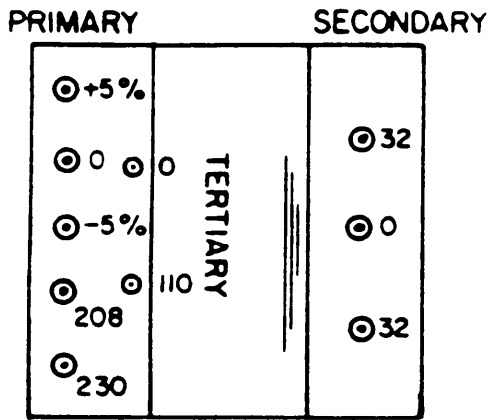

EL6GR003

Figure 2-2. Power Transformer T1, Input Voltage Tap Connections

CAUTION

The $\pm 5\%$ taps are factory pre-set and should be changed only if a unit tends to over- or under-charge. Do not change the tap unless replacing T1.

c. *Operation at 50Hz.* To operate at power line frequency of 50 Hz the timer face plates must be reversed as follows.

(1) Remove 25 screws from the top cover of the charger/analyzer and remove cover.

(2) Remove the three (3) timer knobs by loosening the two setscrews on each knob.

(3) Remove 7 phillips screws and nuts holding the face plate. Hold the nuts to prevent their falling into the charger/analyzer.

(4) Reverse the face plate and reattach using the screws and nuts removed in step (3); replace timer knobs in original position and tighten setscrews.

d. *Installation Checkout.* Refer to the preliminary operation check out procedures given in section 3 to verify that the equipment is properly installed and ready for operation.

CHAPTER 3

OPERATING INSTRUCTIONS

Section 1. CONTROLS AND INDICATORS

3-1. General

This chapter describes operating controls and indicators and operating procedures under usual and unusual conditions. Note that operating procedures are described for typical applications; local requirements may require variations of these steps.

3-2. Controls and Indicators (fig. 3-1)

<i>Control or Indication</i>	<i>Function</i>
Power ON-OFF Switch (CB1) . . .	Controls overall application of power to charger/analyzer circuits and provides circuit protection from overloads and shorts.
POWER RESET Switch (S5) . . .	Momentary pushbutton switch which is depressed to reset power relay and restore overall equipment operation.
FUSE, 1 AMP (FI)	Provides circuit protection for internal equipment timing and control circuits.
DISCHARGE AMP HR Switch (S7)	Three-position rotary switch which selects discharge resistor banks for specific battery discharge rates.
CHARGE AMP HR control (R16)	Variable control sets charges current reference. (One hour rate.)
DISCHARGE AMP control (R15)	Variable control sets discharge current reference. (One hour rate.)
CELL SELECT switch (S6)	Toggle switch adjusts internal EOD and charge comparator circuits to correspond with appropriate number of battery cells.
CURRENT meter (M5)	Center-zero meter continuously indicates charge or discharge current from -100A to +100A.
VOLTAGE meter (M4)	Dual range meter; indicates overall battery voltage on the 0-30V scale, or individual cell voltage on the 0-3V scale (external leads required), depending on position of 30V-3V switch.
30V-3V switch (S3)	Selects voltage range to be monitored by VOLTAGE meter. In 30V position, meter reads charging/discharge battery voltage; in 3V position, ex-

<i>Control or Indicator</i>	<i>Function</i>
(+) and (-) terminals (J4, J3) . .	Provides connection for external test leads.
START switch (S2)	Momentary pushbutton switch depressed to remove unit from a reset state and initiate operation. Lights RUN indicator (DS6) and indicator above appropriate timer (DS1, DS3 or DS5).
RUN indicator (DS6)	Amber lamp lights when START switch is pressed and equipment is in a normal operating cycle.
RESET switch (SI)	Momentary pushbutton switch which is depressed to interrupt operation and restore unit to a logical reset state.
FUNCTION SELECT switch (S4)	Multi-position rotary switch selects equipment operating mode OFF; MANUAL DISCHARGE; MANUAL CHARGE; or AUTO.
AUTO-CHARGE No. 1 timer (M3)	One-hour timer controls first phase of automatic charge cycle-not used during manual charge.
Run indicator (DS5)	Indicates (amber lamp) that AUTO-CHARGE No. 1 timer (M3) is operating.
AUTO/MANUAL DISCHARGE timer	Two-hour timer used during automatic operation for controlled discharge to End-Of-Discharge (EOD); used during manual operation for deep discharge.
FAIL indicator (DS4)	Indicates that end-of-discharge (EOD) occurred before 1 hour (in discharge) elapsed.
Run indicator (DS3)	Amber lamp indicates that AUTO/MANUAL DISCHARGE timer (M2) is operating.
PASS indicator (DS2)	Green lamp indicates that EOD has occurred after 1 hour of discharge
AUTO/MAN CHARGE No. 2 timer (M1)	One-hour timer used during the last phase of the cycle for auto-

<i>Control or Indicator</i>	<i>Function</i>	<i>Control or Indicator</i>	<i>Function</i>
Run indicator (DS1)	Amber lamp indicates the AUTO/MAN CHARGE No. 2	Powercord(P3)	Provides connection to local power source.
		Battery connector (J5)	Provides connection to battery.

Section II. OPERATION UNDER USUAL AND UNUSUAL CONDITIONS

3-3. Operating Procedures

The following are the complete normal operating procedures. For operational checkout procedures after installation, servicing or as a periodic check, refer to paragraph 4-8. Connect dc output connector J5 to the known good battery, connect ac connector P3 to the local ac power source, then perform the following procedures:

CAUTION

Before you connect any nickel-cadmium battery to the charger/analyzer, determine the correct charge/discharge rates and safety precautions by referring to the appropriate battery manual (TM 11-6140-203-14-2, TM 11-6140-203-14-3, or TM 11-6140-203-15-1).

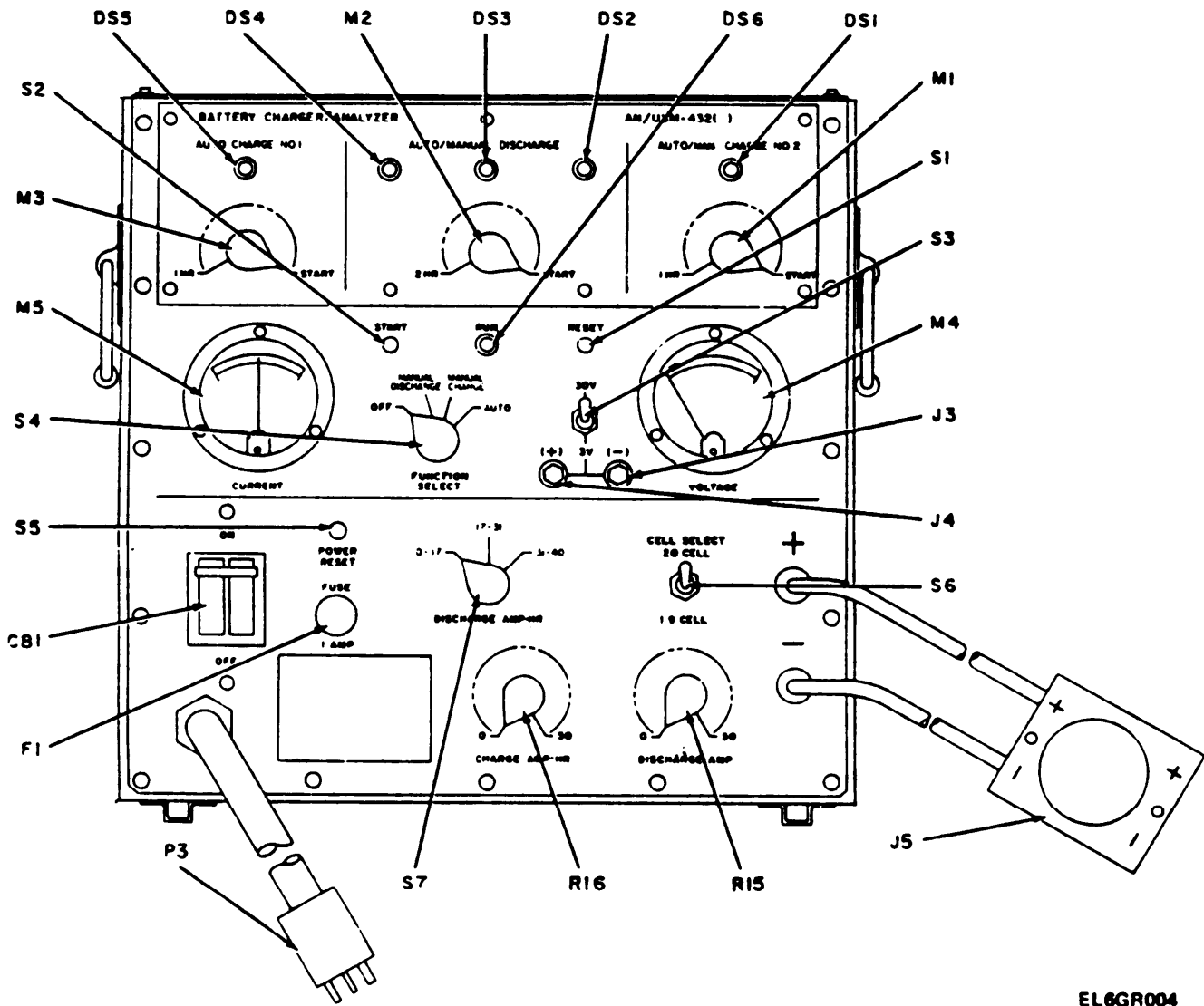

Figure 3-1. Controls and Indicators.

EL6GR004

CAUTION

Before connecting or disconnecting a battery, make sure the charger/analyzer is in RESET. Do not connect or disconnect a battery when the *RUN* light is on.

NOTE

The capacity test (initial discharge) and equalization discharge may be eliminated if discharge racks are used.

a. Phase 1—Capacity Test (Initial Discharge).

Proceed as follows:

- (1) Set ON-OFF switch (CB1) to OFF position.
 - (2) Set CELL SELECT to match battery to be charged.
 - (3) Set AUTO-CHARGE No. 1 timer (M3) fully ccw then back to 1 HR position.
 - (4) Set AUTO/MANUAL DISCHARGE timer (M2) to START position.
 - (5) Set AUTO/MAN CHARGE No. 2 timer (MI) fully ccw then back to 1 HR position.
 - (6) Set ON-OFF switch (CB1) to ON position.
 - (7) press POWER RESET switch (S5) momentarily.
 - (8) Set FUNCTION SELECT switch (S4) to AUTO position.
 - (9) Set 30V-3V switch (S3) to 30V position.
 - (10) Set DISCHARGE AMP-HR switch (S7) to appropriate position for 1-hour rate.
 - (11) Set CHARGE AMP-HR control (R16) to appropriate position for 1-hour rate. Note that battery should trickle-charge during the final 5 to 10 minutes of the charge cycle; adjust control accordingly.
 - (12) Set DISCHARGE AMP control (R15) to appropriate position. Use ammeter for precise setting.
 - (13) If fail light comes on, clear it by moving AUTO-CHARGE No. 1 tier cw then back to 1 HR position.
 - (14) Press START switch (S2) momentarily to initiate operational cycle and observe that the following actions occur.
 - (a) RUN indicator (amber, DS6) illuminates,
 - (b) Discharge indicator (amber, DS3) illuminates.
 - (c) Battery VOLTAGE (M4) and CURRENT (M5) meters display battery condition.
 - (d) PASS (DS2) or FAIL (DS4) indicator illuminate at EOD. PASS indicates that battery discharged for at least 1 hour before reaching EOD.
 - (15) Monitor cell VOLTAGE during the last 15 minutes of discharge.
- b. Phase 2—Equalization (Manual Discharge).* This is a continuation of Phase 1; proceed as follows:
- (1) Set FUNCTION SELECT switch (S4) to MANUAL DISCHARGE position, and the DISCHARGE timer to START position.
 - (2) Press START switch (S2) momentarily to ini-

tiate operational cycle. Unit will discharge battery continuously; cell voltage must be monitored by operator. If desired, set 30V-3V switch (s3) to 3V position, connect test leads to (+) and (-) 3V terminals (J4, J3) and monitor cell voltage on VOLTMETER (M4). Short individual cells in accordance with the battery manual when the monitored cell voltage drops to 0.5 volts; this will ensure that each cell is at zero volts.

(3) Proceed to next phase when cell voltages are at zero (deep discharge).

c. Phase 3, 4, 5—Initial Charge, Capacity Test, Final Charge (Auto Cycle). This is a continuation of Phase 2; proceed as follows:

- (1) Set 30V-3V switch (S3) to 30V position and disconnect any test leads used in phase 2.
- (2) Set AUTO-CHARGE No. 1 timer (M3) to START position.
- (3) Set AUTO/MANUAL DISCHARGE timer (M2) to START position.
- (4) Set AUTO/MAN CHARGE No. 2 timer (MI) to START position.
- (5) Set FUNCTION SELECT switch (S4) to AUTO position.
- (6) Set DISCHARGE AMP-FIR (S7), CHARGE AMP-HR(R-16), DISCHARGE AMP (R-15) and CELL SELECT (S6) to appropriate positions, according to battery type.
- (7) Press START switch (S2) momentarily to initiate automatic cycle and observe that the following actions occur:
 - (a) RUN indicator (DS6) illuminates.
 - (b) Automatic charge indicator (DS5) illuminates.
 - (c) CURRENT meter (M5) reads full scale for less than a second, falls back to 0, then rises again to full scale at next cycle. (Note that unit emits an audible deep vibration each charge cycle, in synchronization with the meter movement).
 - (d) VOLTAGE meter (M4) reads 26-28 volts after 40 to 50 minutes and unit continues to charge battery, at a lower rate, for remainder of cycle. (CURRENT meter (M5) still pulses, but for shorter time periods during each interval; voltage meter is read during non-active part of pulse cycle.
 - (e) Monitor cell VOLTAGE during the last 15 minutes of the charge cycle.
 - (f) After a 60-minute period, AUTO CHARGE NO. 1 timer (M3) stops, the associated run indicator (DS5) extinguishes, AUTO/MANUAL DISCHARGE timer (M2) begins operation and the associated run indicator (DS3) illuminates.
 - (g) Battery discharge continues at a constant rate until EOD is reached (0.95 volts/cell).
 - (h) If EOD is reached after the 60-minute period, PASS indicator (DS2) illuminates, AUTO/MANUAL DISCHARGE time (M2) stops (providing an indi-

cation of actual battery capacity), associated run indicator (DS3) extinguishes, AUTO/MAN CHARGE NO. 2 timer (M1) begins operation and the associated run indicator (DS1) illuminates.

If EOD is reached in less than 60 minutes, FAIL indicator (DS 4) illuminate, timer (M2) stops, and charge is not started.

(i) At the end of the cycle, all indicator extinguish except PASS (DS2) and unit enters a RESET mode.

3-4. Damage from Improper Control Settings

a. Operational Errors. The equipment cannot be damaged from improper control settings. If the operator changes control function settings during mid-cycle, or uses the wrong control settings for the battery parameter, internal detection circuits operate quickly to shut down the unit. If this occurs, recheck for proper control settings and restart unit to complete the interrupted cycle.

b. Resets. During discharge cycle, if charger/analyzer seems to be reset, possibly due to selection of the wrong discharge rate (over-current condition), reselect proper range, set DISCHARGE AMP control (R15) down to 0, re-initiate START (S2) and slowly bring DISCHARGE AMP control (R-15) up to appropriate CURRENT (MS) level for the selected range. Note that this procedure will not operate in automatic discharge if charger/analyzer had failed EOD before 1 hour (FAIL light on). If this condition occurs, reset AUTO CHARGE NO. 1 timer (M3) CW, then back to the timed-out condition; or advance AUTO/MANUAL DISCHARGE timer (M2) past the 1-hour marking. (Perform the former procedure if setting of AUTO/MANUAL DISCHARGE timer (M2) is not to be disturbed.)

3-5. Procedures for Shutdown

Equipment operation can be fully terminated at any time, in the event of failure or external conditions, by setting the ON-OFF circuit breaker (CB1) to OFF position. Disconnect unit from ac power source and from battery connection.

3-6. Operation Under Unusual Conditions

The following precautions should be observed for operation of the equipment where extreme climatic conditions may exist:

a. Operation in Artic Climates. Subzero temperatures and climatic conditions associated with cold weather may adversely affect equipment functioning. Follow these precautions:

- (1) Handle equipment carefully.
- (2) Keep equipment clean and dry.
- (3) Prevent ice from forming on the equipment.

Ice formation may inhibit control operation.

(4) At temperature less than 32°F. (0°C.) neither rated capacity of discharge nor full charge in 1 hour will be obtained.

b. Operation in Desert Climates. Heat and dryness associated with desert environment will not affect the operation of the equipment. However, dust storms can cause controls to bind and damage associated equipment. When the equipment is not in use cover connectors with plastic bags. Do not charge at battery temperatures above 120°F. (49°C.).

CHAPTER 4

OPERATOR/ORGANIZATIONAL MAINTENANCE INSTRUCTIONS

Section 1. TOOLS AND EQUIPMENT

4-1. Scope of Organizational Maintenance

The maintenance duties at this category are listed below together with a reference to the paragraphs covering the specific maintenance functions. The paragraphs include instructions for performing corrective maintenance.

- a.* Repainting and refinishing (para 4-3).
- b.* Daily preventive maintenance checks and services (para 4-6).
- c.* Cleaning (para 4-7).
- d.* Functional test (para 4-8).
- e.* Knob replacement (para 4-9).

4-2. Tools, Materials, and Test Equipment Required for Organizational Maintenance

No special tools or test equipment are required for organizational maintenance. Refer to the maintenance allocation chart (MAC) in appendix B and the following listing:

- a.* Tool Kit, Electronic Equipment TK- 101/G.
- b.* Multimeter AN/URM- 105.
- c.* Trichloroethane.
- d.* Cleaning cloth.
- e.* Fine sandpaper (No. 000).
- f.* Soft bristle brush.
- g.* Paint Gray, Alkali-Resistant.
- h.* Paintbrush.

Section II. REPAINTING AND REFINISHING INSTRUCTIONS

4-3. General

When the finish on the equipment has been badly scarred or damaged, further damage can be prevented by touching up the damaged surfaces, being careful not to paint electrical terminals, especially ground terminals.

4-4. Repainting and Refinishing

Remove dirt from the equipment by cleaning affected areas with trichloroethane or No. 000 sandpaper to complete the preparation for painting. Apply paint with a small brush; brush two thin coats of paint on the bare spots to protect from further deterioration. Refer to TM 43-0139, Painting Instructions for Field Use. Approved paints and finishes are listed in SB 11-573.

Section III. PREVENTIVE MAINTENANCE CHECKS AND SERVICES

4-5. General

Preventive maintenance is the systematic care, servicing, and inspection of equipment to prevent the occurrence of trouble, to reduce downtime, and to maintain the equipment in serviceable condition. Defects that cannot be corrected must be reported to personnel at a higher maintenance category. Routine checks like cleaning, dusting, washing, checking for frayed cables, stowing items not in use, covering unused receptacles and checking for frayed cables, towing items not in use, covering unused receptacles and checking for loose nuts and screws are not listed as preventive maintenance checks or services. They are things that you should do anytime you see they must be done,

4-6. Preventive Maintenance Checks

The functional test procedure in paragraph 4-8 should be used to speedily determine the condition of the charger/analyzer when the equipment is initially installed, reinstalled after removal for any reason, and at least once a week if the equipment is maintained in a standby condition.

4-7. Cleaning

Inspect the exterior surfaces of the equipment. All exterior surfaces should be clean and free of dirt, grease, and fungus.

- a.* Remove dust and loose dirt with a clean, soft cloth.

WARNING

Adequate ventilation should be provided while using TRICHLOROTRIFLUOROETHANE. Prolonged breathing of vapor should be avoided. The solvent should not be used near heat or open flame; the products of

decomposition are toxic and imitating. Since TRICHLOROTRIFLUOROETHANE dissolves natural oils, prolonged contact with skin should be avoided. When necessary, use gloves which the solvent cannot penetrate. If the solvent is taken internally, consult a physician immediately.

Section IV. TROUBLESHOOTING**4-8. Troubleshooting Procedures**

The responsibilities of the organizational repairman are limited to correction of equipment failures which can be remedied by replacement of a defective cable assembly, fuse or knob. All other maintenance procedures relating to test, repair or overhaul are to be accomplished at a higher category of maintenance. To determine the condition of the charger/analyzer when installing initially, reinstalling after repair, or when equipment is maintained in a standby condition, perform the procedure below:

a. Functional Test. Two serviceable batteries are required, preferable in the range of 30-40AH capacity. One should be nearly discharged, the other charged.

CAUTION

Make sure that charger/analyzer is in RESET before disconnecting and reconnecting batteries. Do not connect a battery when the RUN light is on.

(1) Set up the charger/analyzer for automatic operation, Phases 3, 4, 5. (Procedure is in para 3-3.) Connect the discharged battery and start the unit. The ammeter will deflect to nearly full scale for between .4 and .75 seconds, then return to zero. It will repeat this every second (slightly longer at 50 Hz). Move the Charge AMP HR control to higher and lower settings. The charging pulse will be longer at higher settings, shorter at low settings. Return the setting to the proper position for the battery used. Let the unit charge for a few minutes, then press RESET and disconnect the discharged battery. Connect the charged battery and press START. The unit should charge, but as the voltage rises to 28.5 vdc between pulses, the charge current will drop to an indicated 50-70 amperes and the time of the charging pulse will drop to a fraction of the previous time, roughly a tenth of a second. (The time it takes to go to the lower charge rate will depend on the state of charge of the battery). Turn the Charge 1 timer by hand to the 1-hour mark. The unit will switch automatically to Discharge, the Charge 1 light will go off, and the Discharge light will go on.

(2) Observe that the discharge current is constant. Move the Discharge AMP HR control to higher and lower settings to verify that the current can be controlled. When the discharge setting is too high, an internal sensor will trip out the discharge circuit. To reset this

circuit, turn the Discharge AMP HR control to zero, press START, and then set the desired discharge current. Return the control to the original position. Since the Discharge AMP HR switch will be in the 17-31 position, the range of adjustment will be approximately 17 to 31 amperes. Press RESET and disconnect the charged battery. Connect the discharged battery and turn the Charge 1 timer cw until the FAIL light goes off, then turn the timer back until the timer switch clicks. Now press START. The current should remain at set point, and the battery voltage will drop below .95 volts per cell after a few minutes of discharge, the time depending on the remaining charge in the battery. Since 1 hour has not passed, the FAIL light should come on at this point, and the RUN light go off. The unit should stop. This verifies the FAIL logic. Press RESET, disconnect the discharged battery and connect the charged battery. Turn the Charge 1 timer cw until the FAIL light goes off, then turn the timer back until the timer switch clicks. The unit will return to Discharge. Slowly turn the Discharge timer ccw to the 2-hour mark. When it reaches that point, the Charge 2 light should come on and the Discharge light go off. The green PASS light will come on as charging begins.

(3) Turn this Charge 2 timer slowly ccw until the switch clicks. At that point the Charge 2 and RUN lights will go off, charging stops, and the PASS light remains on. This concludes the check of the automatic modes of operation, Phases 3,4,5.

(4) Disconnect the charged battery and reconnect the discharged battery. Set up the charger/analyzer for Manual Discharge (para. 3-3). Allow the unit to run until the battery voltage is below .95 volts per cell. This verifies correct operation of the Manual Discharge circuit (EOD disabled in this mode of operation).

b. Battery Cable Assembly. The battery cable assembly interconnects the battery under charge/test with the equipment via a two-pin MS-type connector, J3; and heavy-duty battery cables. Inspect the connector for general appearance and tightness of contacts. Check battery (+) and (-) contacts for corrosion and sand lightly with No. 000 sandpaper, if necessary. Check cables for frayed wiring or loose connectors. Note that defective contacts are usually indicated by arcing or overheating.

WARNING

Dangerous voltages are present within the equipment. Always disconnect power cable before opening up the unit for inspection or service.

c. Power Cable Assembly. The power cable assembly is a three-wire cable terminated by a 4-pin connector, P3. A defective cable maybe indicated when operation of front-panel switching does not energize the equipment. Check cable continuity; if an open or high-resistance is indicated, the cable is defective and should be replaced.

d. Fuse. Fuse F2 is rated for 100 amperes and protects the charger circuits against external battery cable shorts or reverse connections. If the equipment is energized when ac power is supplied but the battery does not charge, or no voltage is measured on voltmeter (M4) with switch (S3) in the W-volt position, F2 should be suspected. Fuse F2 is located inside the unit at the top right side and is retained by blade-type contacts. Remove the fuse, check continuity and replace, if necessary.

e. Timers. The charge timers control the length of the charge cycle, while the discharge timer determines whether the battery has passed or failed the capacity test. Check the timers for proper switchover points, with the equipment turned off, by turning the timer knobs ccw until a click is heard. The click for the charge timers should occur at the 1 hour point. The click for the discharge timer should occur at the 60 minutes setting. If the switchover points (clicks) occur at other than those times given above, then an adjustment is required. If necessary, the switchover point can be corrected by loosening and readjusting the timer knobs.

4-9. Removal and Replacement of Knobs

Each of the control knob is secured to the respective shaft by two setscrews before removing a knob, set the control to a readily identifiable position so that thereplacement knob can be set accurately to the same original position. To replace a knob, loosen or remove the setscrew and carefully lift the knob from the shaft. Before replacement, check to see that the knob dial pointer tracks properly with dial markings.

APPENDIX A

REFERENCES

DA Pam 310-4	Index of Technical Manuals, Technical Bulletins, Supply Manuals (Types 7, 8, and 9), Supply Bulletins, and Lubrication Orders.
DA Pam 310-7	US Army Equipment Index of Modification Work Orders.
SB 11-573	Painting and Preservation Supplies Available for Field Use for Electronics Command Equipment.
SB 38-100	Preservation, Packaging, Packing and Marking Materials, Supplies and Equipment Used by the Army.
SC 5180-91-CL-R07	Tool Kit, Electronic Equipment TK-105/G (NSN 5180-00-610-8177).
TB 43-0118	Field Instructions for Painting and Preserving Electronics Command Equipment Including Camouflage Pattern Painting of Electrical Equipment Shelters.
TM 11-2019	Test Sets I-49, I-49A and I-49B and Resistance Bridges ZM-4A/U and ZM-4B/U.
TM 11-6140-203-14-2	Operator's, Organizational, Direct Support, and General Support Maintenance Manual for Aircraft Nickel-Cadmium Batteries.
TM 11-6140-203-14-3	Operator's, Organizational, Direct Support and General Support Maintenance Manual: Nonaircraft Nickel-Cadmium Batteries.
TM 11-6140-203-15-1	Operator's, Organizational, Direct Support, and Depot Maintenance Manual: Aircraft and Nonaircraft Nickel-Cadmium Batteries (General).
TM 11-6625-203-12	Operator's and Organizational Maintenance Manual: Multimeter AN/URM-105 and AN/URM-105C (Including Multimeter ME-77/U and ME-77C/U).
TM 11-6625-539-14-4	Operator's, Organizational, Direct Support, and General Support Maintenance Manual: Test Set, Transistor TS-1836D/U (NSN 6625-00-138-7320).
TM 11-6625-654-14	Operator's, Organizational, Direct Support, and General Support Maintenance Repair Parts and Special Tools Lists (Including Depot Maintenance Repair Parts and Special Tools List) for Multimeter AN/USM-223.
TM 38-750	The Army Maintenance Management System (TAMMS).
TM 43-0139	Painting Instructions for Field Use.
TM 740-90-1	Administrative Storage of Equipment.
TM 750-244-2	Procedures for Destruction of Electronics Materiel to Prevent Enemy Use (Electronics Command).

APPENDIX D

MAINTENANCE ALLOCATION

Section I. INTRODUCTION

D-1. General

This appendix provides a summary of the maintenance operations for AN/USM-432. It authorizes categories of maintenance of specific maintenance functions on repairable items and components and the tools and equipment required to perform each function. This appendix may be used as an aid in planning maintenance operations.

D-2. Maintenance Function

Maintenance functions will be limited to and defined as follows:

- a. Inspect.* To determine the serviceability of an item by comparing its physical, mechanical, and/or electrical characteristics with established standards through examination.
- b. Test.* To verify serviceability and to detect incipient failure by measuring the mechanical or electrical characteristics of an item and comparing those characteristics with prescribed standards.
- c. Service.* Operations required periodically to keep an item in proper operating condition; i.e., to clean (decontaminate), to preserve, to drain, to paint, or to replenish fuel, lubricants, hydraulic fluids, or compressed air supplies.
- d. Adjust.* To maintain, within prescribed limits, by bringing into proper or exact position, or by setting the operating characteristics to the specified parameters.
- e. Align.* To adjust sptxified variable elements of an item to bring about optimum or desired performance.
- f. Calibrate.* To determine and cause connections to be made or to be adjusted on instruments or test measuring and diagnostic equipments used in precision measurement. Consists of comparisons of two instruments, one of which is a certified standard of known accuracy, to detect and adjust any discrepancy in the accuracy of the instrument being compared.
- g. Install.* The act of emplacing, seating, or fixing into position an item, part, module (component or assembly) in a manner to allow the proper functioning of the equipment or system.
- h. Replace.* The act of substituting a serviceable like type part, subassembly, or module (component or assembly) for an unserviceable counterpart.
- i. Repair.* The application of maintenance services (inspect, test, service, adjust, align, calibrate, replace) or other maintenance actions (welding, grinding, riveting, straightening, facing, remachining, or resurfacing) to restore serviceability to an item by correcting specific damage, fault, malfunction, or failure in a part, subassembly, module (component or assembly), end item, or system.
- j. Overhaul.* That maintenance effort (service/action) necessary to restore an item to a completely serviceable/operational condition as prescribed by maintenance standards (i.e., DMWR) in appropriate technical publications. Overhaul is normally the highest degree of maintenance performed by the Army. Overhaul does not normally return an item to like new condition.
- k. Rebuild.* Consists of those services/actions necessary for the restoration of unserviceable equipment to a like new condition in accordance with original manufacturing standards. Rebuild is the highest degree of materiel maintenance applied to Army equipment. The rebuild operation includes the act of returning to zero those age measurements (hours, miles, etc.), considered in classifying any equipments/components.

D-3. Column Entries

- a. Column 1, Group Number.* Column 1 lists group numbers, the purpose of which is to identify component, assemblies, subassemblies, and modules with the next higher assembly.
- b. Column 2, Component/Assembly.* Column 2 contains the noun names of components, assemblies, sub assemblies, and modules for which maintenance is authorized.
- c. Column 3, Maintenance Functions.* Column 3 lists the functions to be performed on the item listed in column 2. When items are listed without maintenance functions, it is solely for purpose of having the group numbers in the MAC and RPSTL coincide.
- d. Column 4, Maintenance Category.* Column 4 specifies, by the listing of a "work time" figure in the appropriate subcolumn(s), the lowest level of maintenance authorized to perform the function listed in column 3. This figure represents the active time required to perform that maintenance function at the indicated category of maintenance. If the number or complexity of the tasks within the listed maintenance function vary at different maintenance categories.

appropriate “work time” figures will be shown for each category. The number of task-hours specified by the “work time” figure represents the average time required to restore an item (assembly, subassembly, component, module, end item or system) to a serviceable condition under typical field operating conditions. This time includes preparation time, troubleshooting time, and quality assurance/quality control time in addition to the time required to perform the specific tasks identified for the maintenance functions authorized in the maintenance allocation chart. Sub-columns of column 4 areas follows:

- C-Operator/Crew
- O-Organizational
- F-Direct Support
- H-General Support
- D-Depot

e. Column 5, Tools and Equipment. Column 5 specifies by code, those common tool sets (not individual tools) and special tools, test, and support equipment required to perform the designated function.

f. Column 6, Remarks. Column 6 contains an alphabetic code which leads to the remark in section IV, Remarks, which is pertinent to the item opposite the particular code.

D-4 Tool and Test Equipment Requirements (Sec III)

a. Tool or Test Equipment Reference Code. The numbers in this column coincide with the numbers used in the tools and equipment column of the MAC. The numbers indicate the applicable tool or test equipment for the maintenance functions.

b. Maintenance Category. The codes in this column indicate the maintenance category allocated the tool or test equipment.

c. Nomenclature. This column lists the noun name and nomenclature of the tools and test equipment required to perform the maintenance functions.

d. National/NATO Stock Number. This column lists the National/NATO stock number of the specific tool or test equipment.

e. Tool Number. This column lists the manufacturer’s part number of the tool followed by the Federal Supply Code for manufacturers (5digit) in parentheses.

D-5. Remarks (See IV)

a. Reference Code. This code refers to the appropriate item in section II, column 6.

b. Remarks. This column provides the required explanatory information necessary to clarify items appearing in section II.

SECTION II MAINTENANCE ALLOCATION CHART
FOR

BATTERY CHARGER-ANALYZER AN/USM-432

(1) GROUP NUMBER	(2) COMPONENT/ASSEMBLY	(3) MAINTENANCE FUNCTION	(4) MAINTENANCE CATEGORY					(5) TOOLS AND EQPT.	(6) REMARKS
			C	O	F	H	D		
00	BATTERY CHARGER-ANALYZER AN/USM-432	Inspect Test Inspect Service Test Replace	0.1 3.0	0.2 0.2 0.2 0.3				10 2 2 1 2 4,5,6,9	A B A C D E F
01	CONTROL BOARD ASSEMBLY	Replace Repair Overhaul Test Replace Test Repair				1.0 1.0 1.0 0.2 0.2	40	3 3 3 3, 4 thru 11 4,5 3 4,5,7,8 3	

**SECTION III TOOL AND TEST EQUIPMENT REQUIREMENTS
FOR**

BATTERY CHARGER-ANALYZER AN/USM-432

TOOL OR TEST EQUIPMENT REF CODE	MAINTENANCE CATEGORY	NOMENCLATURE	NATIONAL NATO STOCK NUMBER	TOOL NUMBER
1	0	MULTIMETER, AN/URM-105	6625-00-581-2036	
2	0	TOOL KIT, ELECTRONIC EQUIPMENT TK-101/G	5180-00-064-5178	
3	H, D	TOOL KIT, ELECTRONIC EQUIPMENT TK-105/G	5180-00-610-8177	
4	H, D	MULTIMETER, AN/USM-223	6625-00-999-7465	
5	H, D	OSCILLOSCOPE, AN/USM/281C	6625-00-106-9622	
6	H, D	STOP WATCH	6645-00-903-1696	
7	D	TEST SET, SEMICONDUCTOR DEVICE TS-1836D/U	6625-00-138-7320	
8	D	BRIDGE, IMPEDANCE ZM-71/U	6625-00-236-1536	
<u>ADDITIONAL AUTHORIZATION LIST</u> AAL				
9	C, O, H, D	BATTERY, VENTED NI-CD, 24 VOLT 5 TO 40 H.H.		
10	D	BATTERY CHARGER-ANALYZER AN/USM-432		
11	D	EXTENDER TEST BOARD		

SECTION IV. REMARKS

REFERENCE CODE	REMARKS
A	EXTERIOR
B	OPERATIONAL
C	CONTINUITY FUSES, POWER CABLES, LAMPS
D	FUSES, POWER CABLES, ELCON CONNECTOR, LED INDICATORS, KNOBS
E	EVERYTHING
F	ALL EXCEPT CONTROL BOARD

By Order of the Secretary of the Army:

E. C. MEYER
General, United States Army
Chief of Staff

Official:

J. C. PENNINGTON
Major General, United States Army
The Adjutant General

DISTRIBUTION:

Active Army:

HISA (Ft Monmouth) (21)

USAINSCOM (2)

COE (1)

TSG (1)

USAARENBD (1)

DARCOM (1)

TRADOC (2)

OS MAJ COMD (4)

TECOM (2)

USACC (4)

MDW (1)

Armies (2)

Corps (2)

Svc Colleges (1)

USASIGS (5)

USAADS (2)

USAFAS (2)

USAARMS (2)

USAIS (2)

USAES (2)

USAICS (3)

USARMIS (1)

MAAG (1)

USAERDAA (1)

USAERDAW (1)

Ft Carson (10)

Ft Gillem (10)

Ft Gordon (10)

Ft Richardson

(CERCOM OFC) (2)

USA Dep (1)

Sig Sec USA Dep (1)

Army Dep (1) except:

SAAD (30)

SHAD (2)

TOAD (14)

Units Org Under Fol TOE:

29-207 (2)

29-610 (2)

ARNG: None.

USAR: None.

For explanation of abbreviations used, see AR 310-50.



SOMETHING WRONG WITH THIS MANUAL?

THEN... JOT DOWN THE DOPE ABOUT IT ON THIS FORM, TEAR IT OUT, FOLD IT AND DROP IT IN THE MAIL!

FROM: (YOUR UNIT'S COMPLETE ADDRESS)

Commander
Stateside Army Depot
ATTN: AMSTA-US
Stateside, N.J. 07703

DATE 10 July 1975

PUBLICATION NUMBER

TM 11-5840-340-12

DATE

23 Jan 74

TITLE

Radar Set AN/SPS-76

BE EXACT... PIN-POINT WHERE IT IS

PAGE NO.	PARA-GRAPH	FIGURE NO.	TABLE NO.
2-25	2-28		
3-10	3-3		3-1
5-6	5-8		
		F03	

IN THIS SPACE TELL WHAT IS WRONG AND WHAT SHOULD BE DONE ABOUT IT:

Recommend that the installation antenna alignment procedure be changed throughout to specify a 2° IFF antenna lag rather than 1°.

REASON: Experience has shown that with only a 1° lag, the antenna servo system is too sensitive to wind gusting in excess of 20 knots, and has a tendency to rapidly accelerate and decelerate as it hunts, causing strain to the drive train. Hunting is minimized by adjusting the lag to 2° without degradation of operation.

Item 5, Function column. Change "2 db" to "3db."

REASON: The adjustment procedure for the TRANS POWER FAULT indicator calls for a 3 db (500 watts) adjustment to light the TRANS POWER FAULT indicator.

Add step f.1 to read, "Replace cover plate removed in step e.1, above."

REASON: To replace the cover plate.

Zone C 3. On J1-2, change "+24 VDC to "+5 VDC."

REASON: This is the output line of the 5 VDC power supply. + 24 VDC is the input voltage.

TYPED NAME, GRADE OR TITLE, AND TELEPHONE NUMBER

SSG I. M. DeSpirito 999-1776

SIGN HERE:

SSG I. M. DeSpirito

DA FORM 2028-2
1 AUG 74

P.S.--IF YOUR OUTFIT WANTS TO KNOW ABOUT YOUR MANUAL "FIND" MAKE A CARBON COPY OF THIS AND GIVE IT TO YOUR HEADQUARTERS.

TEAR ALONG DOTTED LINE



SOMETHING WRONG WITH THIS MANUAL?

THEN... JOT DOWN THE DOPE ABOUT IT ON THIS FORM, TEAR IT OUT, FOLD IT AND DROP IT IN THE MAIL!

FROM: (YOUR UNIT'S COMPLETE ADDRESS)

DATE

PUBLICATION NUMBER

TM 11-6130-413-12

DATE

9 Apr 80

TITLE

BE EXACT... PIN-POINT WHERE IT IS

PAGE NO.

PARA-GRAPH

FIGURE NO.

TABLE NO.

IN THIS SPACE TELL WHAT IS WRONG AND WHAT SHOULD BE DONE ABOUT IT:

TEAR ALONG DOTTED LINE

TYPED NAME, GRADE OR TITLE, AND TELEPHONE NUMBER

SIGN HERE:

FILL IN YOUR
UNIT'S ADDRESS

FOLD BACK

DEPARTMENT OF THE ARMY

Commander
US Army Communications and
Electronics Materiel Readiness Command
ATTN: DRSEL-ME-MQ
Fort Monmouth, New Jersey 07703

FOLD BACK

TEAR ALONG DOTTED LINE

THE METRIC SYSTEM AND EQUIVALENTS

WEIGHT MEASURE

1 Centimeter = 10 Millimeters = 0.01 Meters = 0.3937 Inches
 1 Meter = 100 Centimeters = 1000 Millimeters = 39.37 Inches
 1 Kilometer = 1000 Meters = 0.621 Miles

WEIGHTS

1 Gram = 0.001 Kilograms = 1000 Milligrams = 0.035 Ounces
 1 Kilogram = 1000 Grams = 2.2 lb.
 1 Metric Ton = 1000 Kilograms = 1 Megagram = 1.1 Short Tons

LIQUID MEASURE

1 Milliliter = 0.001 Liters = 0.0338 Fluid Ounces
 1 Liter = 1000 Milliliters = 33.82 Fluid Ounces

SQUARE MEASURE

1 Sq. Centimeter = 100 Sq. Millimeters = 0.155 Sq. Inches
 1 Sq. Meter = 10,000 Sq. Centimeters = 10.76 Sq. Feet
 1 Sq. Kilometer = 1,000,000 Sq. Meters = 0.386 Sq. Miles

CUBIC MEASURE

1 Cu. Centimeter = 1000 Cu. Millimeters = 0.06 Cu. Inches
 1 Cu. Meter = 1,000,000 Cu. Centimeters = 35.31 Cu. Feet

TEMPERATURE

$5/9(^{\circ}\text{F} - 32) = ^{\circ}\text{C}$
 212° Fahrenheit is equivalent to 100° Celsius
 90° Fahrenheit is equivalent to 32.2° Celsius
 32° Fahrenheit is equivalent to 0° Celsius
 $9/5^{\circ}\text{C} + 32 = ^{\circ}\text{F}$

APPROXIMATE CONVERSION FACTORS

TO CHANGE	TO	MULTIPLY BY
Inches	Centimeters	2.540
Feet	Meters	0.305
Yards	Meters	0.914
Miles	Kilometers	1.609
Square Inches	Square Centimeters	6.451
Square Feet	Square Meters	0.093
Square Yards	Square Meters	0.836
Square Miles	Square Kilometers	2.590
Acres	Square Hectometers	0.405
Cubic Feet	Cubic Meters	0.028
Cubic Yards	Cubic Meters	0.765
Fluid Ounces	Milliliters	29.573
its	Liters	0.473
arts	Liters	0.946
allons	Liters	3.785
Ounces	Grams	28.349
Pounds	Kilograms	0.454
Short Tons	Metric Tons	0.907
Pound-Feet	Newton-Meters	1.356
Pounds per Square Inch	Kilopascals	6.895
Miles per Gallon	Kilometers per Liter	0.425
Miles per Hour	Kilometers per Hour	1.609

TO CHANGE	TO	MULTIPLY BY
Centimeters	Inches	0.394
Meters	Feet	3.280
Meters	Yards	1.094
Kilometers	Miles	0.621
Square Centimeters	Square Inches	0.155
Square Meters	Square Feet	10.764
Square Meters	Square Yards	1.196
Square Kilometers	Square Miles	0.386
Square Hectometers	Acres	2.471
Cubic Meters	Cubic Feet	35.315
Cubic Meters	Cubic Yards	1.308
Milliliters	Fluid Ounces	0.034
Liters	Pints	2.113
Liters	Quarts	1.057
ers	Gallons	0.264
ms	Ounces	0.035
ograms	Pounds	2.205
Metric Tons	Short Tons	1.102
Newton-Meters	Pounds-Feet	0.738
Kilopascals	Pounds per Square Inch	0.145
ometers per Liter	Miles per Gallon	2.354
ometers per Hour	Miles per Hour	0.621



PIN : 044373-001